



Vehicle Systems Integration with Hybrid and Electric Drives

Karina Morley

Global Vice President – Control and Electronics

October 23, 2008



1923 Le Zèbre passenger car



**Bugatti Veyron
The world's fastest
production car**

Hybrid Types and the Functionality They Offer



Full/Strong Hybrids

	12 V Micro Hybrid	Belt/Crank Mounted ISG Hybrid	Power Split Hybrid	2 Mode Hybrid	Series Hybrid
Engine Start/Stop at Idle	✓	✓ ✓	✓ ✓ ✓	✓ ✓ ✓	✓ ✓ ✓
Regenerative Braking		✓ ✓	✓ ✓	✓ ✓	✓ ✓ ✓
Torque Boost		✓	✓ ✓	✓ ✓	✓ ✓
Engine Operation Separated from Driver Demand		✓	✓ ✓	✓ ✓	✓ ✓ ✓
Electric Only Driving			✓ ✓	✓ ✓	✓ ✓ ✓



What is the Best Energy Storage Device?

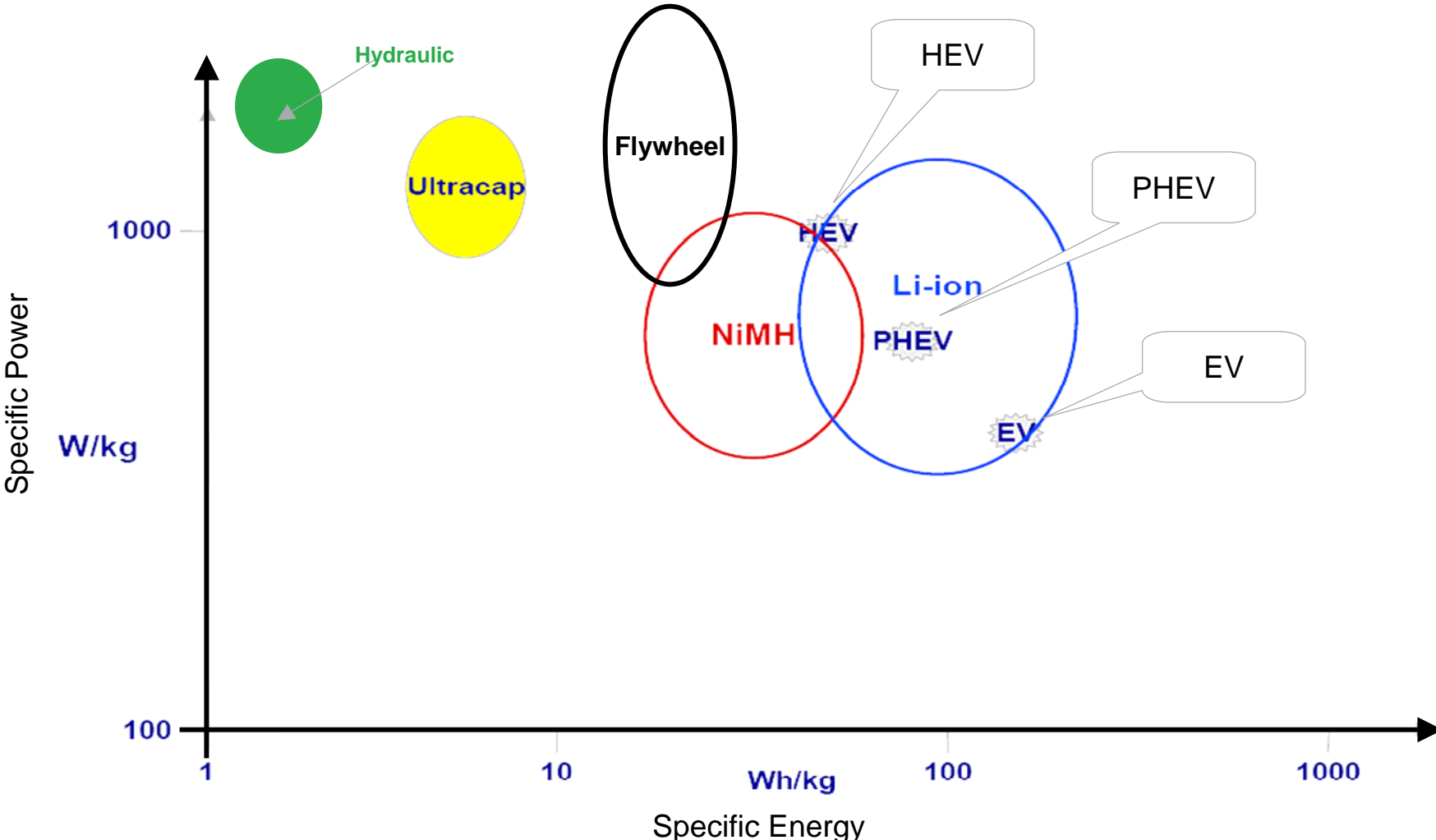

The Vehicle Level Requirements Flow Down to the Subsystems of a Hybrid System

E/M efficiency map considerations

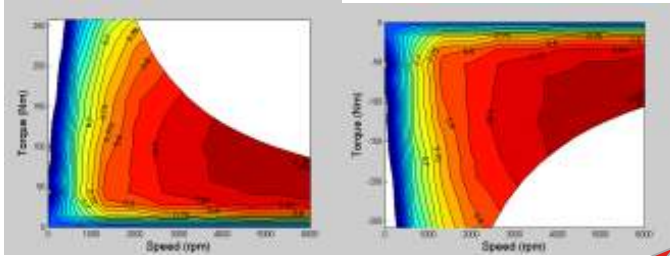

Transmission shift map optimisation

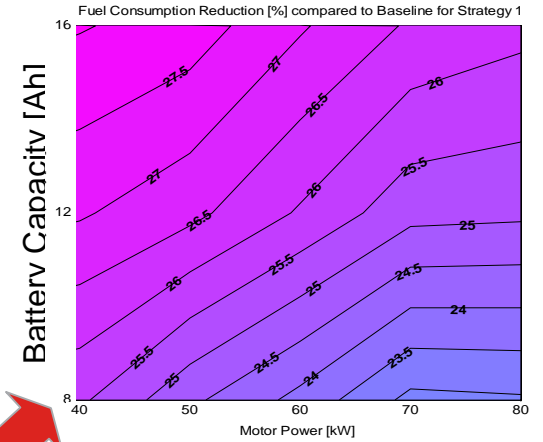
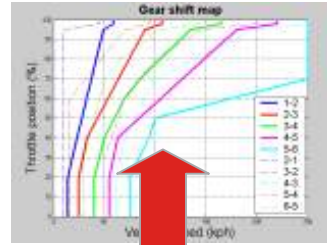

Motor/Battery optimisation

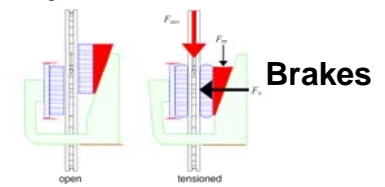

Brakes



Steering

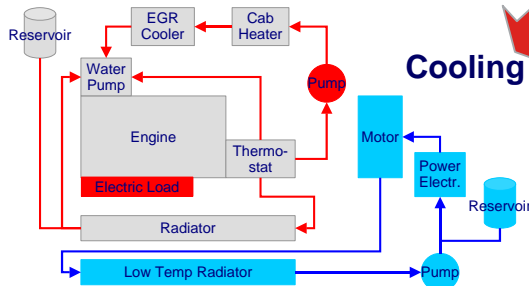
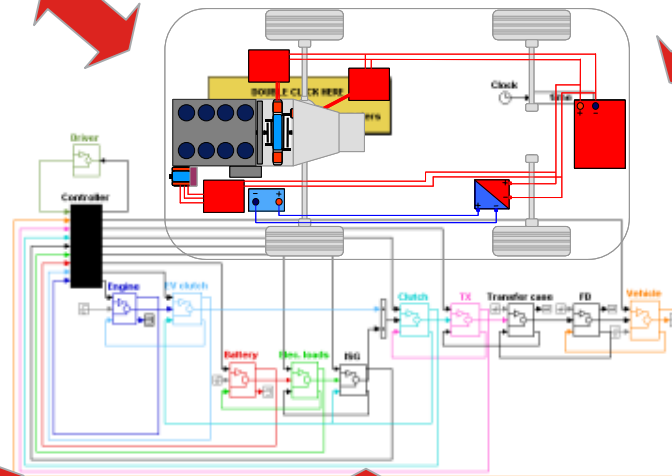

Cooling

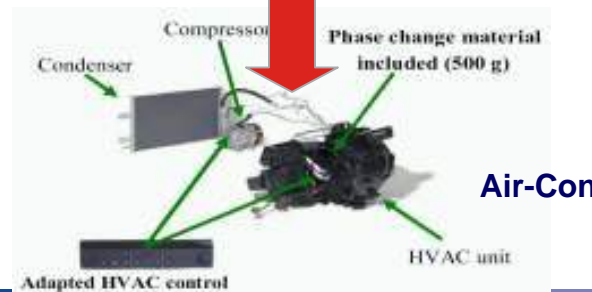

Air-Con

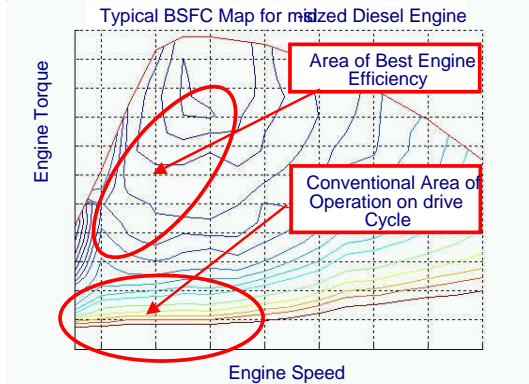

Typical BSFC Map for mixed Diesel Engine

Area of Best Engine Efficiency

Conventional Area of Operation on drive Cycle

To Achieve System Optimality, Traditional Components Have to be Controlled in Non-traditional Ways

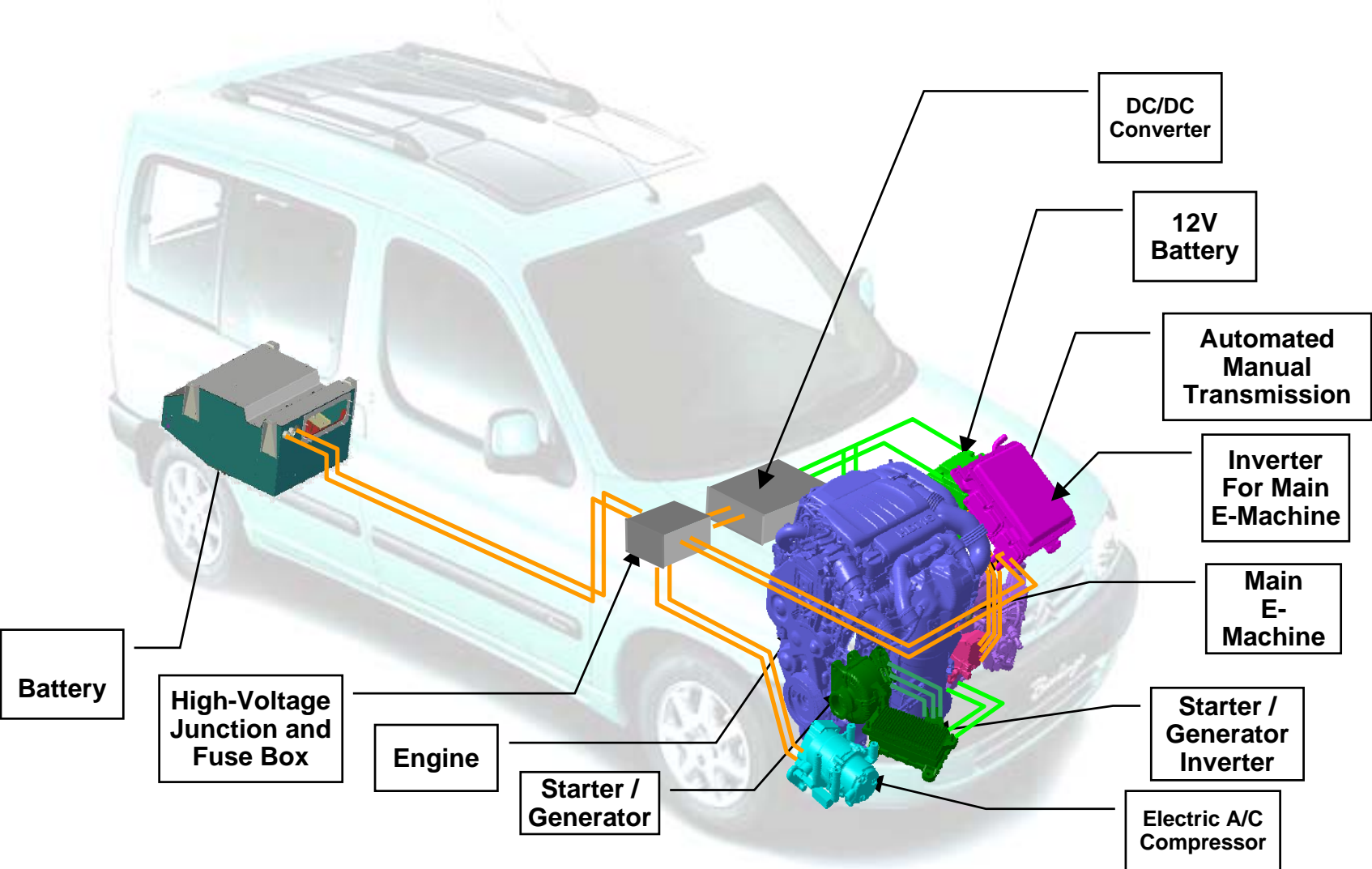

Step by Step Derivation of Energy Storage Requirements

Step 1: Vocation and Drive Cycle Analysis

Inputs

- Drive Cycle
- Vehicle Parameters

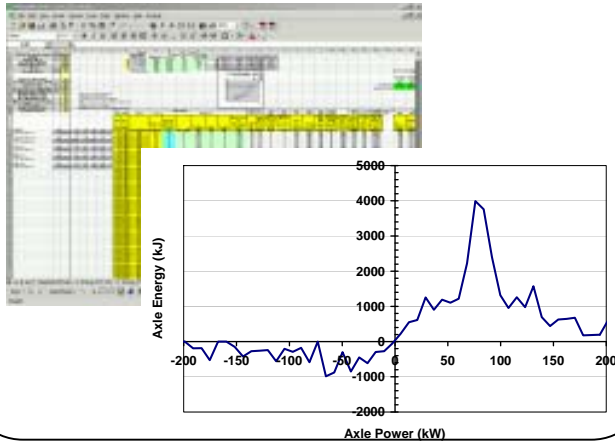

Vocation and Drive Cycle Analysis

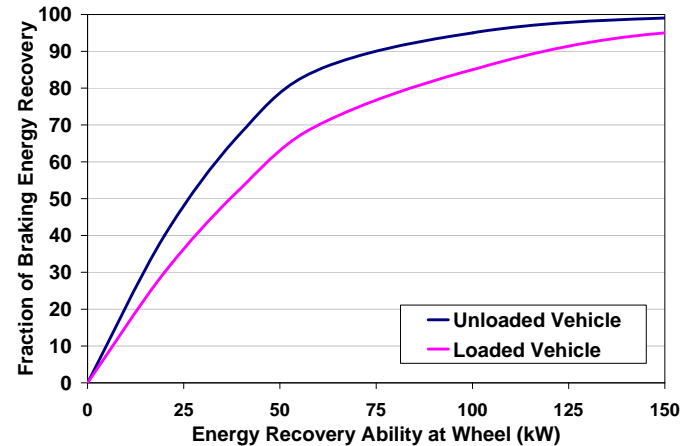

Questions Answered:

- *Is this an application that will benefit from hybridization?*
- *Should I use an electric or a hydraulic hybrid?*

Step by Step Derivation of Energy Storage Requirements

Step 2: Design Point Component Sizing

Inputs

- Vehicle design points
 - Top vehicle speed of 65 mph
 - 20% gradeability
 - Acceleration: 0-30mph in <15 seconds
- Hybrid architecture
 - May be pre-defined (IP, experience, etc.)
 - May evaluate sub-set of options

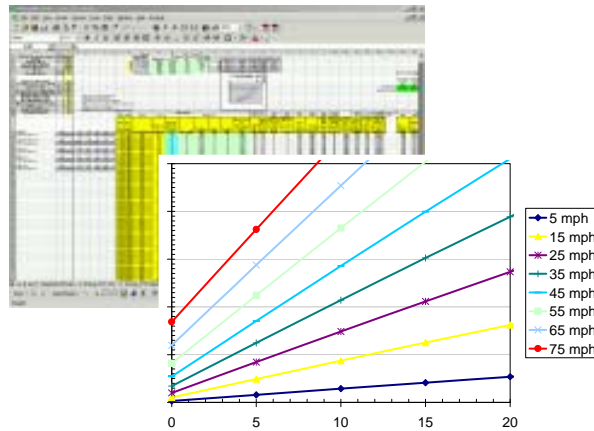
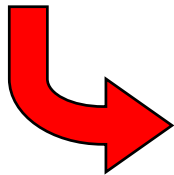

Design Point component Sizing

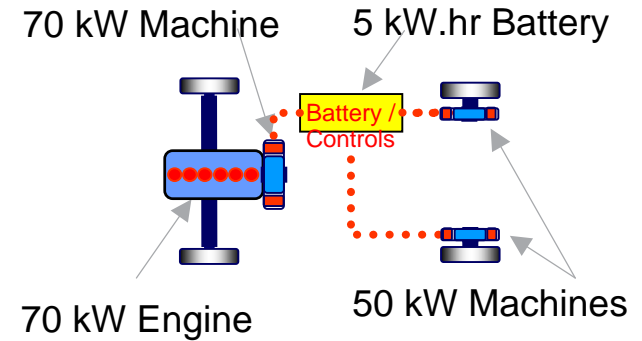
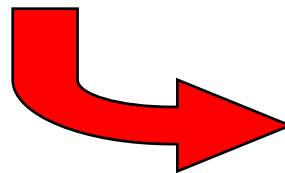

Questions Answered:

- **Can I downsize the engine?**
- **What are the sizes of the components?**

Step by Step Derivation of Energy Storage Requirements

Step 3: Detailed System Modeling & Trade Studies

Inputs

- Design concepts
- Engine and vehicle parameters
- Hybrid component parameters
 - Simple efficiency maps
 - Detailed system models

Core Vehicle Model

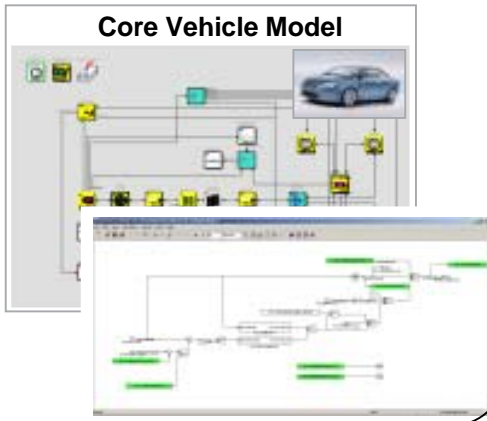

System Simulation

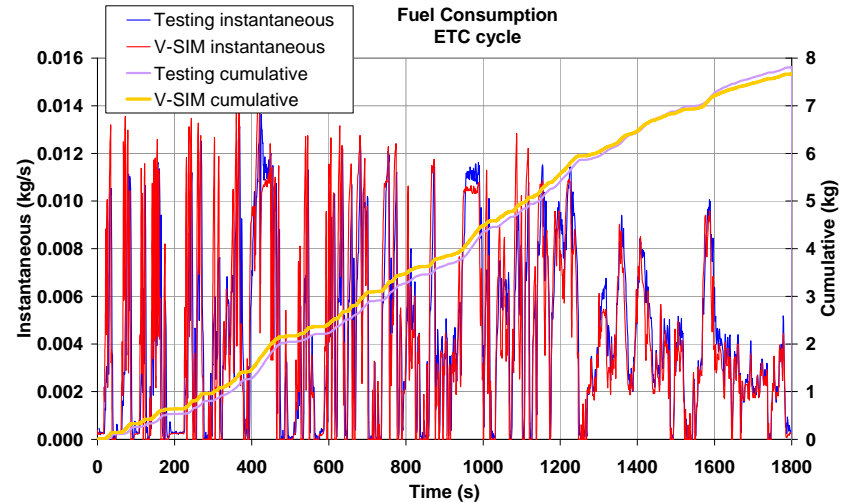

Questions Answered:

- ***What type of fuel economy benefit is expected from the hybrid concepts?***
- ***What are the power and energy requirements for the energy storage system?***

The Energy Storage System Has to Meet Other Requirements for Production Implementation

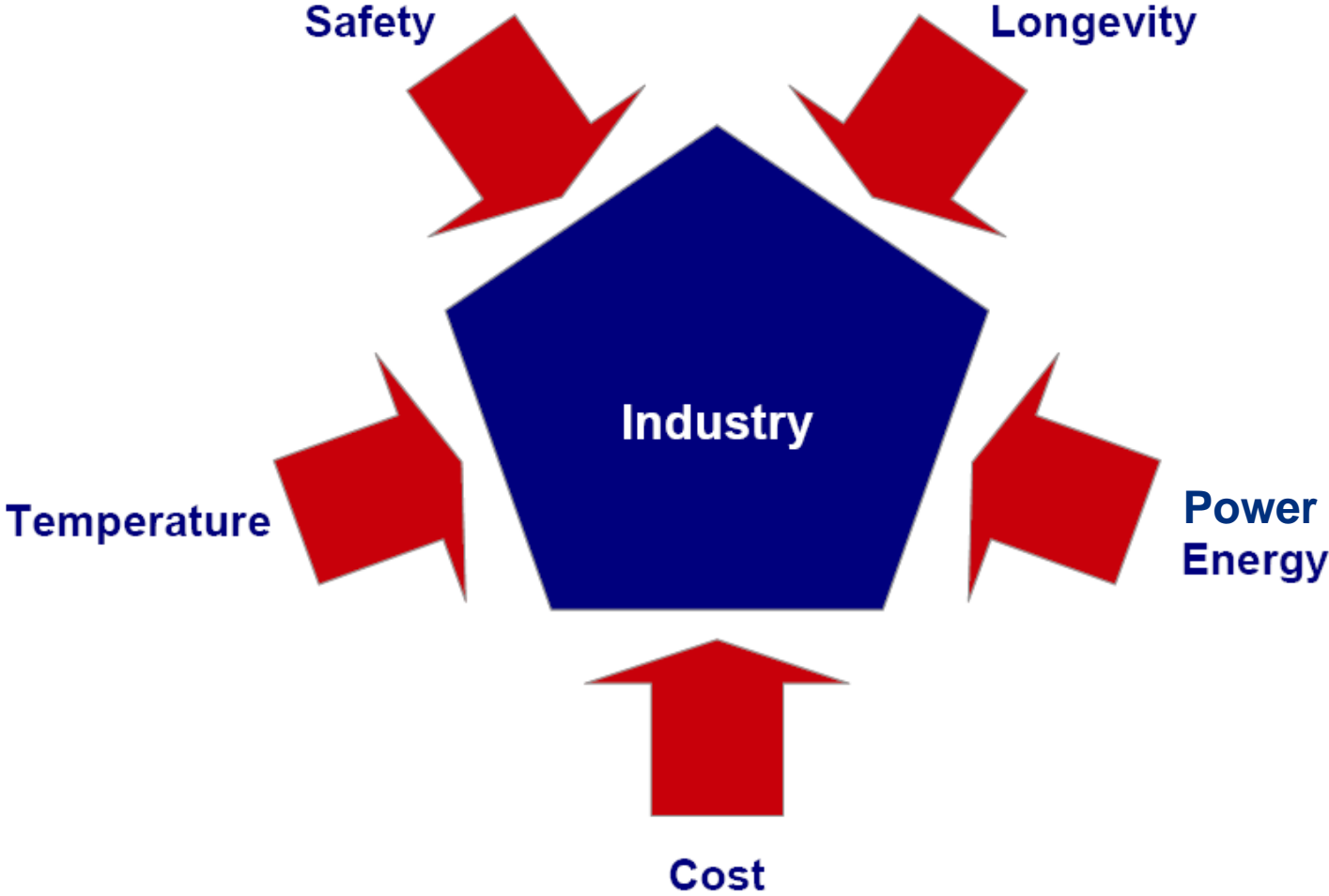

Virtual Vehicle Validation





Chery 'Green Messenger' Vehicle



- We are in a revolutionary stage of engineering as we move into increased electrification of vehicles.
- This is an emerging, evolving market with many unknowns
- A systems engineering approach is key to determining a robust and cost effective solution
- Need for deep knowledge in both hybrids and batteries to successfully provide most reliable and cost effective solution